



Industrial Insulation Group, LLC

A Calsitel/Johns Manville Joint Venture

Fire Protection Systems

Super Firetemp®

Electric Cable Tray Installation

Guide Specification and Installation Instructions

Part 1 – General

- 1.01 Description of System
 - A. This fireproofing system shall be a complete system of fireproofing materials supplied as specified by the Industrial Insulation Group.
 - B. This system shall be designated for application on steel or aluminum cable trays.
- 1.02 Quality Assurance
 - A. Supplier Qualifications: The Super Firetemp® system as supplied by the Industrial Insulation Group is approved for use on the project.
 - B. Applicator Qualifications: Applicators bidding on this work represent that they are fully apprised of the Industrial Insulation Group Super Firetemp® products and installation procedures.
- 1.03 Submittals
 - A. Product Data: Copies of the Industrial Insulation Group Super Firetemp® Application Data and Recommended Guide Specification.
 - B. Samples: Samples of the Industrial Insulation Group Super Firetemp®, Super Calstik® and other applicable materials as requested.
- 1.04 Product Delivery, Storage and Handling
 - A. Materials shall be delivered in packaged lots; clearly marked with the Industrial Insulation Group’s name, brand and type of material.
 - B. Materials shall be stored in a clean, dry warehouse with careful handling to avoid damage.
- 1.05 Job Conditions
 - A. Environmental Conditions: When installing the Industrial Insulation Group Super Firetemp®, conditions must be above freezing to allow the Super Calstik® Glue to set.
 - B. Ventilation: When the Industrial Insulation Group Super Firetemp® is saw-cut in the field, workers must follow personal protection as indicated in the product warning label or Material Safety Data Sheet (MSDS).
 - C. Coordination: Fireproofing must be coordinated with other construction to avoid retrofits that would interfere with the integrity of the finished fireproofing job. At the same time, the fireproofing should be applied as late as possible to minimize the possibility of incidental damage to the finished system.
- 1.06 Codes
 - A. Install all the Industrial Insulation Group Super Firetemp® in strict accordance with all published, applicable regulations by local, state or federal agencies that may have jurisdiction.

Part 2 – Products

2.01 Industrial Insulation Group Super Firetemp®

- A. Guide Specification: Shall be the Industrial Insulation Group Super Firetemp®, a press-molded xonotlite calcium silicate board possessing such strength and resiliency as to be installable without damage. The thickness shall be specified to meet the fire rating requirement of the project, as recommended below. If intended for exterior use or where water resistance is required, the Industrial Insulation Group Super Firetemp® must be protected with an approved system.

Ratings (Minutes to Electrical Failure)

	E 119	UL 1709 (Hi-Rise)
1" (25 mm)	30	15
1.5" (38 mm)	45	30

B. Typical Average Properties:

	Super Firetemp M
Density, pcf (kg/m³)	28 (449)
Compressive Strength @ 10% deformation, psi (kPa)	900 (6206)

- C. Positive Protection: The Industrial Insulation Group Super Firetemp® offers “positive” protection because the thickness is fixed at the manufacturing level under rigid quality control.
- D. Easy Application
 - D.1 May be field-installed using ordinary tools: hammer and nails, automatic nailer, drywall screws and power screwdriver. Screws are the preferred method of attachment.
 - D.2 May be field-cut using a circular saw equipped with a carbide-tipped blade or a saber saw equipped with a metal cutting blade. For minimum on-site effort, precut in a shop. Field cuts with a circular saw should be made by using a “clamped-in-place” straightedge for the saw to follow.
- E. Hazardous Warning
 - E.1 For the latest health and safety information for this product, please refer to the Industrial Insulation Group Material Safety Data Sheet (MSDS) or contact the Industrial Insulation Group at (800) 525-0017.
 - E.2 Contains no asbestos.

2.02 Miscellaneous Materials:

- A. Drywall screws (Length = 2 x Super Firetemp® M thickness); the Industrial Insulation Group Super Calstik® and metal banding (½" [13 mm] wide with retaining clamps).

Super Firetemp®

Electric Cable Tray Installation

Part 3 – Execution

3.01 Inspection

- A. Verify that the cable trays to be fireproofed are as represented in the design criteria.
- B. Verify that all cable trays to be fireproofed have been properly installed.

3.02 Board Installation

- A. Cut boards for the sides of the tray, the height of the tray plus three board thicknesses, plus ½" (13 mm).
- B. Cut boards for the bottom of the tray, the width of the tray (including connecting bolts) plus ½" (13 mm) on each side.
- C. Cut boards for the top of the tray, the width of the bottom piece, plus two board thicknesses.
- D. Cut attachment strips the width of the tray and a minimum of 3" (76 mm) wide.
- E. Secure the attachment strips to the top and bottom of the tray using ½" (13 mm) metal banding. The banding is drawn tight using a banding tool and secured with a retaining clamp at the side of the tray.
- F. Position attachment strips approximately 24" (610 mm) on centers; they are used to back up all bottom butt joints. The strips overlap each bottom piece of the butt joint by a minimum of 1½" (38 mm).
- G. Attach the bottom sections to the attachment strips using five staggered screws for the mid-span strips and three screws on each piece of the butt joint.
- H. Attach the side pieces to the bottom pieces using screws on 8" (203 mm) centers and 1½" (38 mm) from the butt ends. The butt ends are buttered with Super Calstik®. The sides must be installed square and level to allow the top pieces to fit squarely with no gaps. The butt joints between adjacent bottom, side and top pieces should be positioned at least 6" (152 mm) away from one another.

I. Attach the top pieces to the sides using screws on 8" (203 mm) centers and 1½" (38 mm) from the butt ends. The butt ends are buttered with Super Calstik® except at access panels.

J. Access panel butt joints are backed up with strips of Super Firetemp® of the same thickness as the assembly and extending across the full interior dimension of the assembly. The strips overlap the butt ends by 1½" (38 mm) and are secured to the permanent top piece by drywall screws. The access cover is held in place by drywall screws 8" (203 mm) on center.

For best results, predrill undersize holes through the cover and into the sideboard, followed by enlarging the holes in the cover for clearance on the maximum O.D. of the screws. The undersize holes, mentioned above, should be the diameter of the screw at the base of the thread. If the attachment holes become worn after several removals of the access cover, new holes must be made.

K. If the Industrial Insulation Group Super Firetemp® is installed in outdoor conditions where water resistance is required, the Industrial Insulation Group Super Firetemp® must be protected with an approved system.

Super Firetemp®

Electric Cable Tray Installation

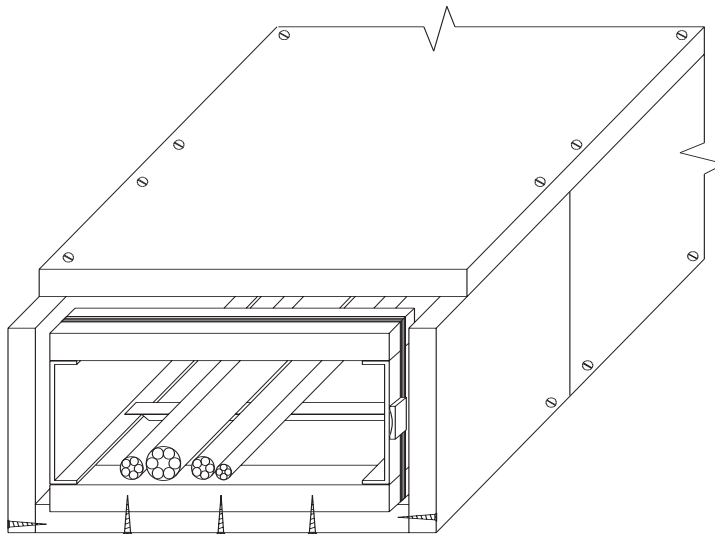

SUPER FIRETEMP®	RATING (MIN.)	
	E 119	UL 1709
1.0" (25 mm)	30	15
1.5" (38 mm)	45	30



Industrial Insulation Group, LLC
A CalSilt/Johns Manville Joint Venture

TYPICAL INSTALLATION
ELECTRIC CABLE TRAY FIRE PROTECTION

DATE 3/98

DRAWING NO. ECT1

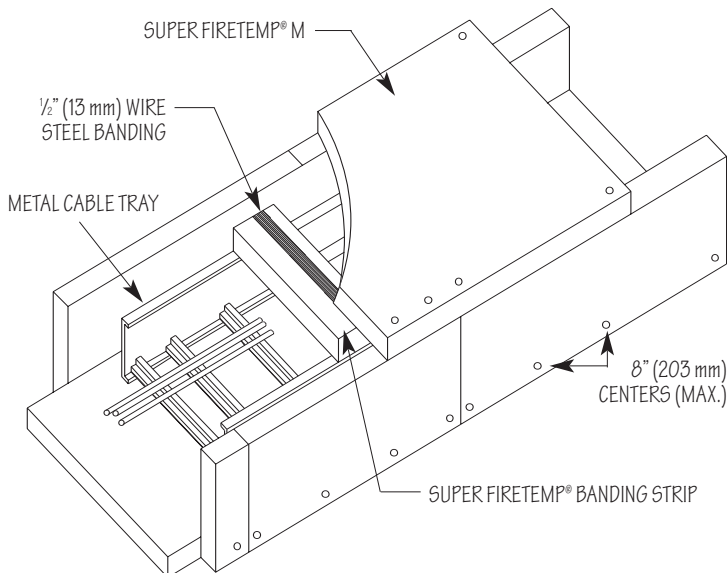

NOTES:

1. BANDING STRIPS ARE POSITIONED EVERY 24" (610 mm).
2. ALL BUTT JOINTS ON BOTTOM BOARD MUST BE COVERED BY A BANDING STRIP.
3. SCREWS ARE 8" (203 mm) O.C., AND 1 1/2" (38 mm) FROM BUTT JOINTS.
4. SEAL ALL BOTTOM AND SIDE JOINTS WITH SUPER CALSTIK® GLUE.



Industrial Insulation Group, LLC
A CalSilt/Johns Manville Joint Venture

TYPICAL INSTALLATION
ELECTRIC CABLE TRAY FIRE PROTECTION

DATE 3/98

DRAWING NO. ECT2

Super Firetemp®

Electric Cable Tray Installation

Note: For technical information and assistance regarding application information, code approvals and performance specifications, call **(800) 872-0338**. If this piece is more than one year old, please contact the Industrial Insulation Group for the current information.

**For Customer Service
and Order Placement**
(800) 525-0017
Fax: (970) 858-6248

**For Sales
Information**
(800) 866-3234
Fax: (877) 758-6096

**For Technical
Information**
(800) 872-0338
Fax: (970) 858-9641



Industrial Insulation Group, LLC
A CalSillite/Johns Manville Joint Venture

1110 16 Road
Fruita, CO 81521
www.iig-llc.com

IIG-501 4-04 (Replaces 8-01)

The physical and chemical properties of the Super Firetemp® presented herein represent typical, average values obtained in accordance with accepted test methods and are subject to normal manufacturing variations. They are supplied as a technical service and are subject to change without notice. Any references to numerical flame spread or smoke developed ratings are not intended to reflect hazards presented by these or any other materials under actual fire conditions. Check with the Customer Service Office to assure current information. **All Industrial Insulation Group products are sold subject to the IIG Limited Warranty and Limitation of Remedy. For a copy of the IIG Limited Warranty and Limitation of Remedy, call (800) 334-7997.**

Copyright © 2004 Industrial Insulation Group
Printed in USA